

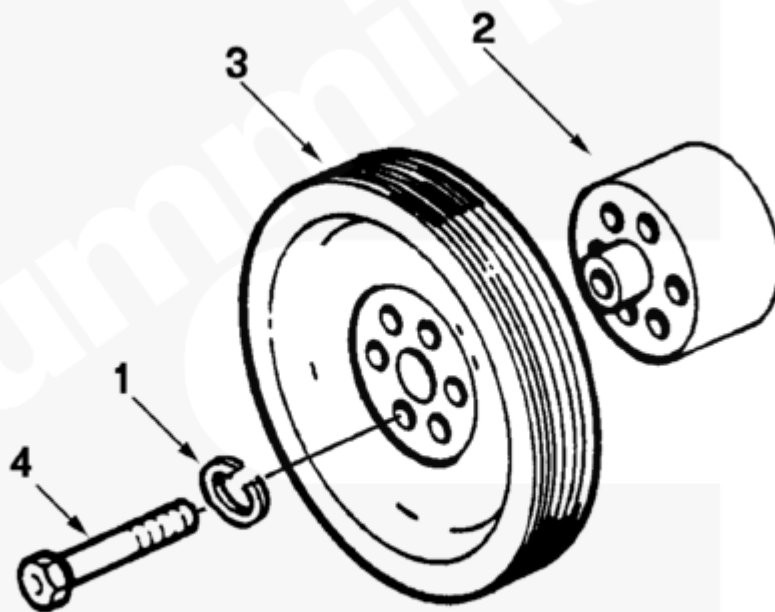

Parts Catalog - Option Detail

Electronic Parts Catalog - Option Detail				
Option	Group	Graphic	Film Card	Date
DA1099	01.02.2	da100gp	F	15-AUG-91
Engines	NH/NT 855, NT495, NT743, NTA855 N106			

©Cummins Inc



da100gp

SMALL | MEDIUM | LARGE

Cart	Ref No	Part Number	Part Description	Required	Remarks
View My Cart					
		DA1099	Vibration Damper		
					Vibration Damper
					Two groove bolt-on front
					crankshaft pulley, 6.69inches
					in diameter. For SAE 7/8inch

					belts.
<input type="checkbox"/>	1	S 608	Lock Washer	6	1/2 in.
<input type="checkbox"/>	2	43002 1	Crankshaft Spacer	1	
<input type="checkbox"/>	3	20765	Air Compressor Pulley	1	
<input type="checkbox"/>	4	205357	Twelve Point Cap Screw	6	1/2 - 13 x 3 3/4 inch

© 2019 Cummins Inc., Box 3005, Columbus, IN 47202-3005 U.S.A.
Terms of Use and Disclaimers | Recommended System Requirements
Need Assistance? Please click on the Contact Us button in the top right corner of any page.